



Installation Instructions

TGS01A Tailgate Spreader

IMPORTANT: Installation Instructions, Parts List, Maintenance Instructions, and Warranty Information. Place in vehicle glove box after installation.

FULL ONE-YEAR WARRANTY

Manufacturer will repair, or at manufacturer's discretion will replace any part of this salt spreader which proves to be defective in workmanship or material under normal use for a period of one year from the date of delivery to the original purchaser. Any cost incurred in returning the product to the supplier is the responsibility of the consumer.

EXCLUSIONS

Manufacturer shall not be liable for special, incidental, or consequential damages, or for damages resulting from lack of necessary maintenance, from misuse, abuse, acts of God, or alteration of the product. Some states do not allow the exclusion or limitation of incidental or consequential damages, so the above limitation or exclusion may not apply to you.

GENERAL INFORMATION

Caution: Disconnect battery before beginning installation.

Check contents of box against Parts List to determine all are correct and included.

Do not tighten bolts and nuts until mounting is complete (unless otherwise specified), then be sure to tighten all attaching parts to the specified torque. (See Chart A.)

When ordering parts refer to Parts List for correct part numbers.

INSTALLATION INSTRUCTION

NOTE: For easy installation, Buyers Products recommends that the vehicle be equipped with a step bumper. If step bumper is not available use mounting angles (0203000 sold separately) to provide lower support for spreader frame. Relocate license plate holder and lights if blocked by any part of spreader.

1. Assemble and install angles and braces. Refer to Fig. 1.

a. Locate center of tailgate and place a chalk mark as guide for centering the spreader.

b. Refer to Fig. 1 and assemble angles and braces (19, 20, and 22) as shown. Do not tighten any bolts yet.

2. Install spreader assembly. Refer to Fig. 1.

a. Position spreader assembly on rear step bumper and align mounting adaptor (19) with holes in angle (20). Make certain frame uprights are vertical, then adjust to stop against spreader frame. Drill holes in mounting adaptor (19). Fasten frame to angle as shown.

b. Drill and bolt bottom of frame through step bumper.

c. Tighten all bolts and nuts as per the torque chart.

3. Electrical installation. Refer to Fig. 4.

a. Find a location for the speed control that is convenient for the driver, noting whether mounting bracket will be attached to the top or bottom of speed control. Attach mounting bracket to vehicle dash or floor. **Make certain speed control is grounded by attaching black ground wire to a suitable vehicle ground or negative post of battery.**

b. Route the blue wire from the speed control location to the vehicle fuse panel and attach to a switched terminal on the panel. This terminal must only be "live" when the ignition is "ON". **Do not** attach blue wire to speed control at this time.

c. Attach the eyelet end of the 96" red wire to the positive terminal of the battery and route the plug end to the location of the speed control. **Do not** attach to speed control at this time.

d. Take the 222" red wire and route the large rubber plug end to the rear of the truck, securely fastening to vehicle frame. Be certain wire is clear of any sharp or moving objects or the vehicle's exhaust system.

CAUTION: Some vehicles are designed to operate with exhaust temperatures as high as 1800° F. This can easily damage any wires which are routed too closely or allowed to come in contact with any portion of the exhaust system. Be certain all wires are securely installed away from the exhaust system.

e. Attach the socket and dummy plug chain to vehicle bumper or other solid mounting point using #8-32X1" screws and #8-32 lock nuts. Be certain the motor leads will not be strained when the plug is attached. Plug the 222" red wire into the socket. Secure black wire from socket to a good grounding point on vehicle frame. Clean all rust or undercoating from this area.

f. Connect spreader and truck wiring harnesses together by plugging together plug into socket. If spreader is removed from vehicle, protect the socket using dummy plug.

g. Perform the motor run test as described in "Caution" box. If the motor operates the blue wire, 222" red wire and

96" red wire can be attached to their respective terminals on the speed control.

4. Operation of spreader:

a. It is recommended to check for free rotation of the auger spinner before operating the spreader due to possible build-up of material between the auger and neck of the hopper.

CAUTION: When filling hopper, make certain there are no large objects contained in the material which could cause the auger spinner to bind and stop operation of the spreader motor. If this should happen, the circuit breaker becomes over loaded and will automatically break the circuit. Allow the motor to cool and clear the auger before pushing the reset button.

b. Fill hopper with #1 rock salt or calcium chloride from bags. Do not use bulk material. All material must have the same crystal size as #1 rock salt.

5. Maintenance Instructions:

Maintenance requirements for the spreader during the winter season are very simple. Occasionally inspect for loose bolts and nuts. Inspect for improper ground, broken wires, frayed or cracked wire insulation. Replace as necessary. Remove salt from unit to minimize corrosion.

To keep maintenance to a minimum, the following cautions are suggested:

a. Do not attempt to clear auger or spinner or to perform any other maintenance or repair work on this spreader unless the ignition switch is in the "OFF" position.

b. Salt must be loose and free from lumps and must be kept dry.

c. Empty hopper after each use and hose the spreader off.

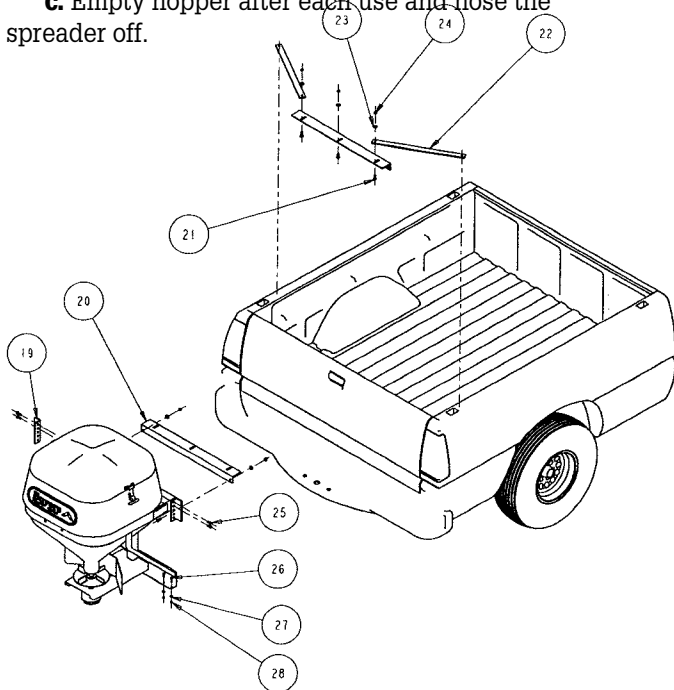

Fig. 1 Mounting

CAUTION:

READ THIS! Serious damage to speed control will result if the following precautions are not followed:

1). Do not install speed control until all other wiring is installed and motor is test-run.

2). After all wires are in place, but before connecting speed control, connect a jumper wire between the red wire from the battery, to the red wire to the motor. The motor should run, indicating proper grounding and wire installation. Remove jumper wire.

3). After the motor has successfully been test run, the speed control can be installed. Do not allow the orange wire from the control to accidentally contact any grounded object, including the control case itself.

Failure to follow these precautions could cause the orange (output) wire from the speed control to make contact with ground, causing the transistor to burn up. Any grounding or shorting of the orange (output) wire which results in a burned transistor is not covered by warranty.

d. When the spreader is no longer being used, remove it from the tailgate. Remove any rust or corrosion from the metal parts, then prime and paint. Store spreader in a suitable location and attach dummy plug to sockets to protect from corrosion.

Chart A Torque

BOLT-NUT SIZE	TORQUE (ft-lbs)
1/4-20	6.0
5/16-18	11.0
3/8-16	20.0

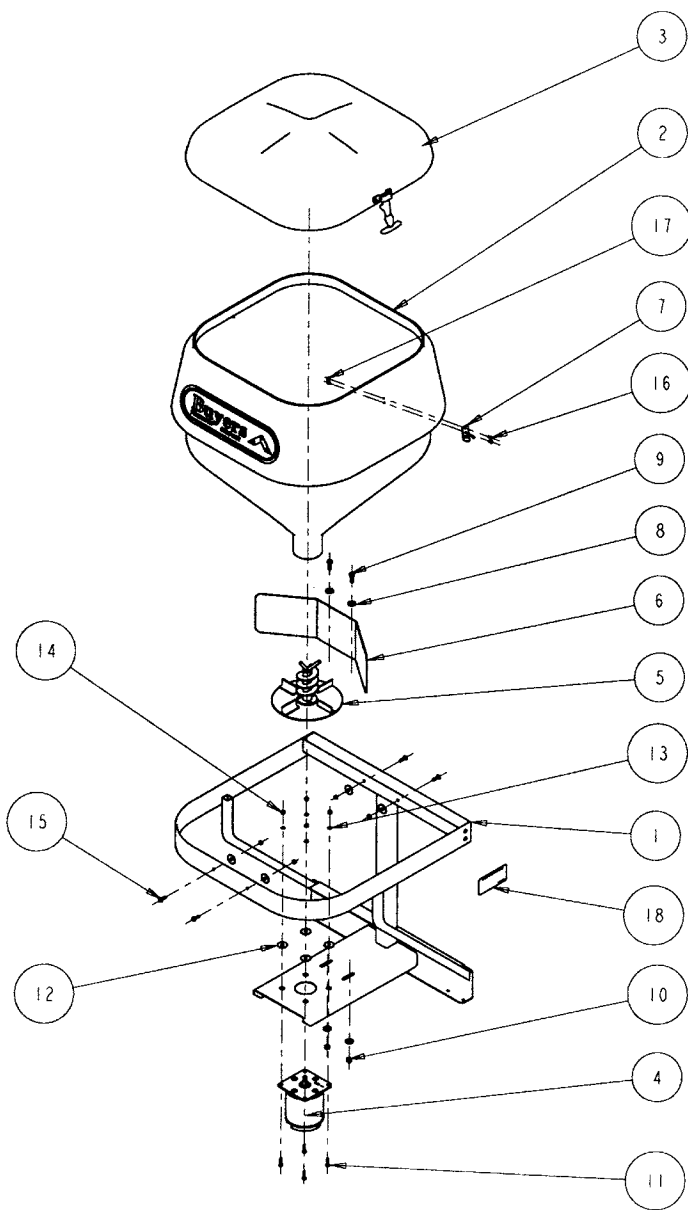

Fig. 2 Main Assembly

Bill of Materials

ITEM NO.	PART NO.	QTY.	DESCRIPTION
1	3003082	1	Frame Weldment, TGS01A
2	3003078	1	Hopper with Sleeve, Assembly, TGS01A
3	3003079	1	Lid, Assembly, TGS01A
4	0202000	1	Motor, 12 VDC
5	0208000	1	Assembly, Auger TGS01
6	3002486	1	Shield, Spinner, TGS05A
7	3000626P	2	Keeper, Latch WJ201 Black
8	FWF038100007SS	4	Washer, Flat 3/8 USS SST
9	FCS038016100SS	2	Screw, HHC 3/8-16 x 1 304 SST
10	FNE038016044SS	2	Nut, Nylock 3/8-16 x 7/16 SST
11	FCS0205020100SS	4	Screw, Cap Hex HD 1/4-20 x 1 SST
12	3001158	8	Washer, Fender 5/16 ID x 1.25 OD
13	FWL025050006SS	4	Washer, 1/4 Spring Lock SST
14	FNE025020031SS	8	Nut, Nylon Insert 1/4-20 SST
15	FCB025020100SS	4	Bolt, Carriage 1/4-20 x 1 SST
16	FBSH01002450SS	4	Screw, BHC #10-24 x .5 SST
17	FNE010024024SS	4	Nut, Elastic Stop 10-24 SS
18	0204000	1	Decal, TGS Warning
19	3003617	2	Angle, Mounting Adaptor, TGS01A
20	3003620	2	Angle, Mounting, TGS01A Spreader
21	FCB038016125	5	Bolt, RHSON 3/8-16 x 1-1/4 GR5 ZN
22	3003973	2	Mount Brace, TGS01A
23	FWF038100007	11	Washer, Flat 3/8 USS ZN
24	FNE038016044	11	Nut, Nyloc 3/8-16 x 7/16 ZN
25	FCS038016100	6	Screw, HHC 3/8-16 x 1 GR 5 ZP
26	FCS025020100	4	Screw, Cap Hex HD 1/4-20 x 1 GR 5 ZN
27	FWF025063007	4	Washer, Flat 1/4 SAE
28	FNE025020031	4	Nut, Nylon Insert 1/4-20 ZN

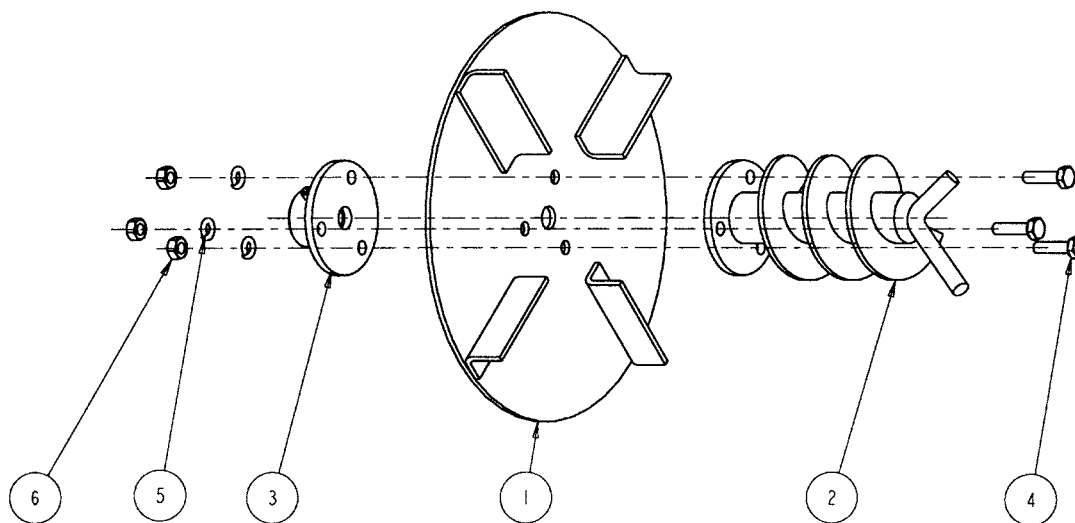
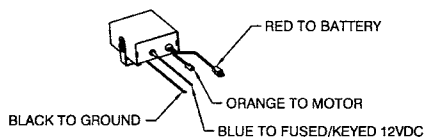

Fig. 3 Auger/Shaft Assembly

Bill of Materials

ITEM NO.	PART NO.	QTY.	DESCRIPTION
1	0202600	1	Weldment, Spinner Plate, TGS01
2	0202100	1	Weldment, TGS Auger
3	0202800	1	Hub, Spinner Finished
4	FCS025020100SS	3	Screw, Cap Hex HD 1/4-20 x 1 SST
5	0205700	3	Washer, 1/4 Split Lock ZN
6	FNH02502021SS	3	Nut, Hex 1/4-20 SST



Speed Control - Rear View

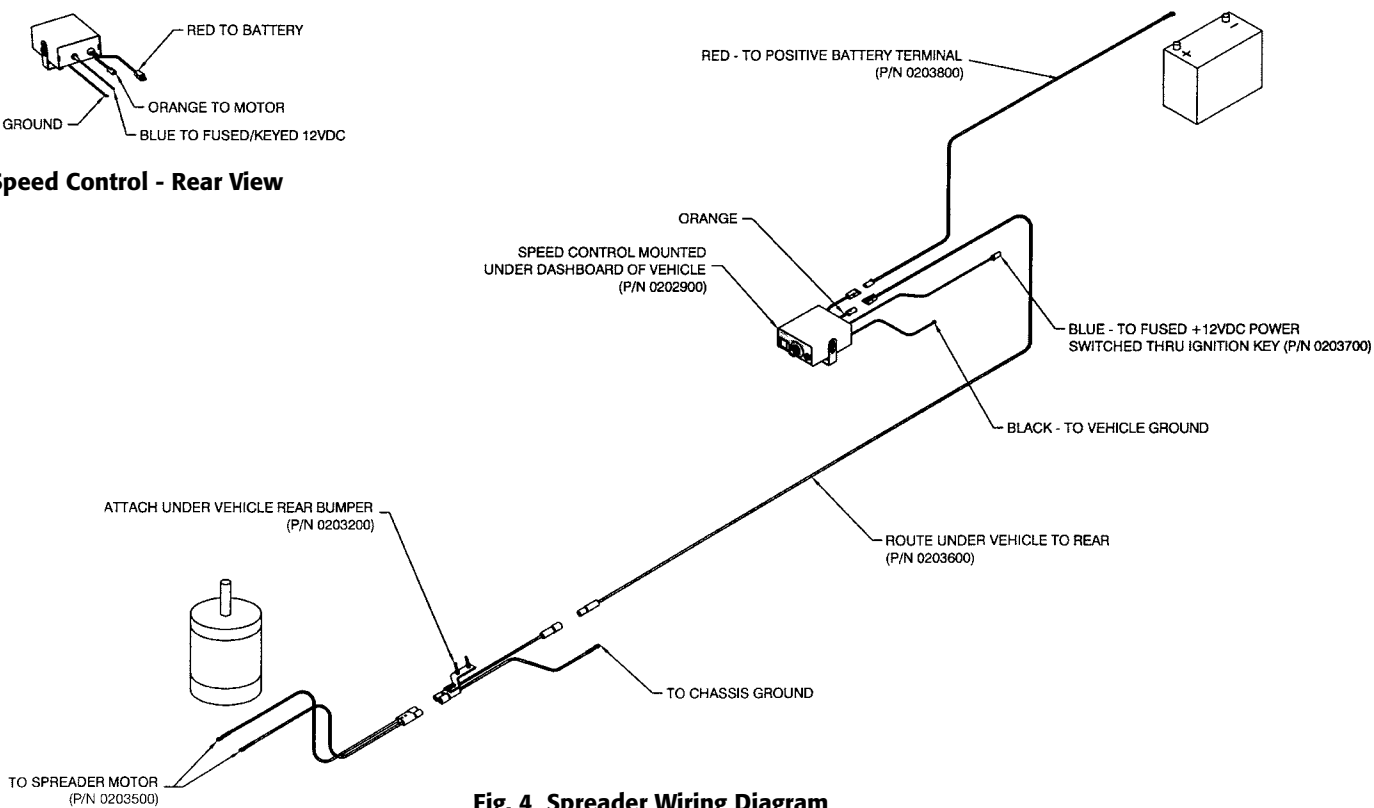

Fig. 4 Spreader Wiring Diagram