

Installation Instructions

TGSUV1 SUV Salt Spreader

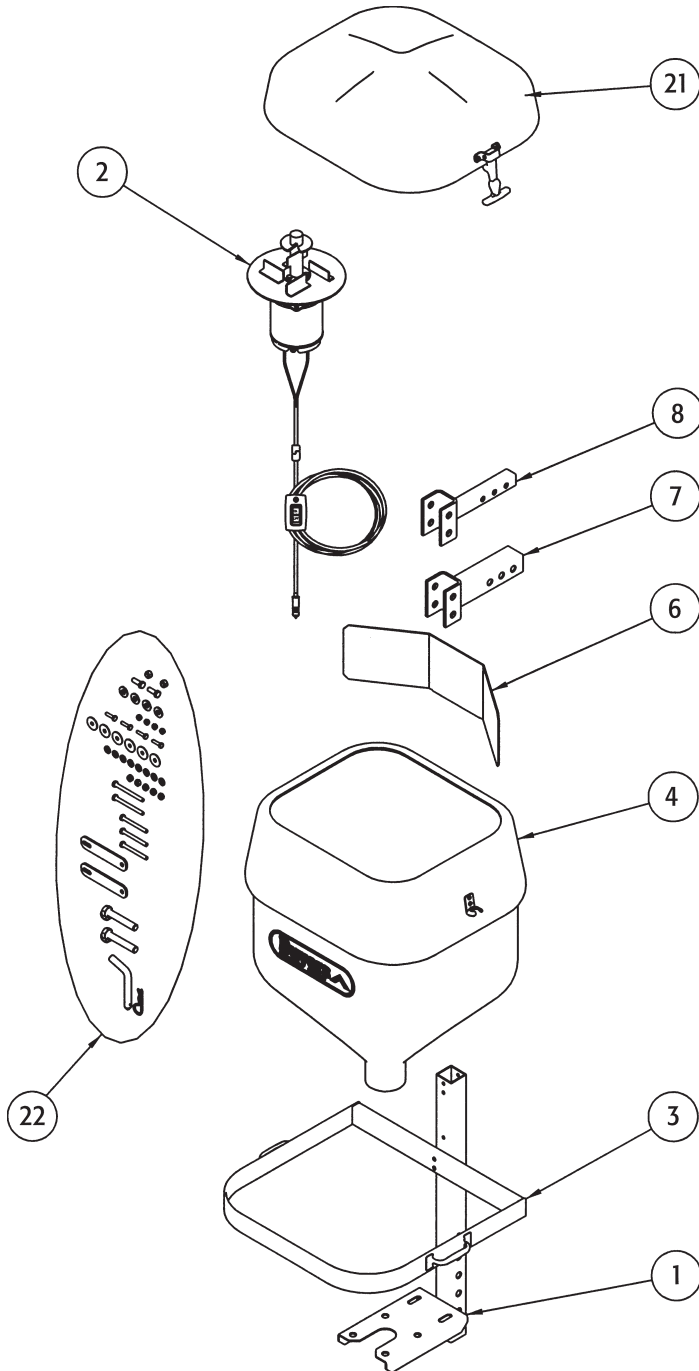

Fig. 1



Bill of Materials

ITEM NO.	PART NO.	QTY.	DESCRIPTION
1	3003572	1	Frame, TGSUV1 Welded Assembly
2	3003579	1	Motor Spinner Assembly, TGSUV1
3	3003902	1	Band, TGSUV1, Weldment
4	3003715	1	Hopper, w/Insert & Graphics, Assy., TGSUV1
5	3003578	2	Strap, Support, TGSUV1
6	3002486	1	Shield, Spinner, TGS05A
7	3003576	1	Receiver Mount, TGSUV1 Weldment
8	3003924	1	Receiver Mount, 1-1/4, Weldment, TGSUV1
9	3000544	2	Screw, HH 5/8 x 3.5 Gr. 5 Zinc
10	FNE063011069	2	Nut, Nylock 5/8-11
11	FWF031075006SS	8	Washer, 5/16 SAE SST
12	FCS031018300SS	3	Screw, HH Cap 5/16-18 x 3 SST
13	92401113A	2	Screw, HH Cap 5/16-18 x 3-1/2 SST
14	FNE031018034SS	5	Nut, Nylock 5/16-18 SS
15	3001158	6	Washer, Fender 5/16 ID x 1.25 OD
16	FCS025020100SS	4	Screw, Cap Hex HD 1/4-20 x 1 SST
17	FNE025020031SS	4	Nut, Nylon Insert 1/4-20 SST
18	FWF038100007SS	4	Washer, Flat 3/8 USS SST
19	FCS038016100SS	2	Screw, HHC 3/8-16 x 1 304 SST
20	FNE038016044SS	2	Nut, Nylock 3/8-16 x 7/16 SST
21	3003580	1	Lid, TGSUV1 Assembly
22	3003831	1	Hardware Bag (includes all above hardware)

Spreader Assembly

See Fig. 1

Check contents of box against parts list to make sure all components are included. When ordering replacement or spare parts, refer to parts list for part numbers.

Tools Needed for Assembly

3/8" or 1/2" drive ratchet with 7/16", 1/2", 9/16" & 15/16" sockets.

7/16", 1/2", 9/16" & 15/16" wrench.

Motor & Frame

See Fig. 2

Mount motor (2) to frame (1) with four 1/4-20 x 1 screws and nuts (15,16,17). The motor screws should be installed along with the large flat washers from the top side as shown in Fig. 2. Do not tighten the screws at this time. The motor will have to be aligned with the hopper later.

Hopper & Band

See Fig. 3

Slide the support band (3) over the hopper (4) from the bottom until it touches the hopper lip. Slide the hopper/band assembly over the top of the frame tube until the holes in the hopper and band line up with the holes in the frame tube. Install 5/16-18 x 3 1/2 HH cap screws (13) from the outside of the frame tube at the top through the band and hopper. Install large washer (15) and nut (14) from the inside. Install 5/16-18 x 3 HH cap screw through the lower hole in the frame, into the hopper, and attach large washer and nut from the inside of hopper. See Fig. 3.

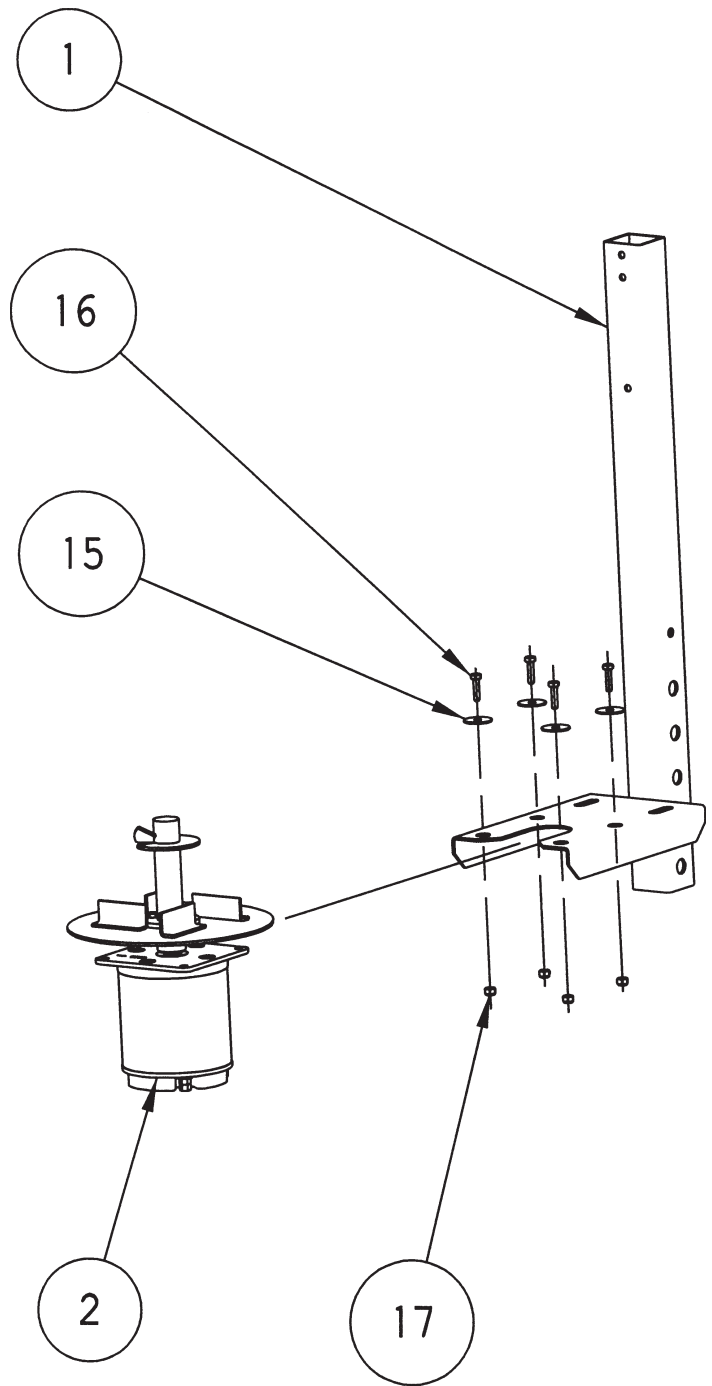

Fig. 2

Bottom Support Straps & Motor Alignment

See Fig. 4

Install bottom support straps (5) by sliding 5/16-18 x 3 HH cap screws through the support straps, frame and hopper *as shown in Fig. 4*. **CAUTION:** do not over tighten the screw that goes through the hopper; you may damage the hopper. At this time the motor should be aligned so that the auger does not rub any part of the hopper outlet. Move the motor around with the screws loose and turn the auger BY HAND to check for rubbing. When the motor is in the correct position tighten the motor screws and recheck one more time for rubbing.

Spinner Shield & Receiver Mount

See Fig. 5

Install the spinner shield (6) with 3/8-16 x 1 HH cap Screws, flat washers and hex nuts (18,19, 20). Position the shield about a 1/2" away from the spinner plate and centered to start with. The shield position can be changed to alter the salt pattern if needed. Install 2" or 1-1/4" receiver mount (7 or 8) at a position that allows the motor to clear any obstacles (rocks, curbs landscape ties, etc.) We recommend the bottom most set of holes (at the motor end) to start with. Use 5/8 x 3-1/2 HH cap screws and hex nuts (9, 10) and tighten securely.

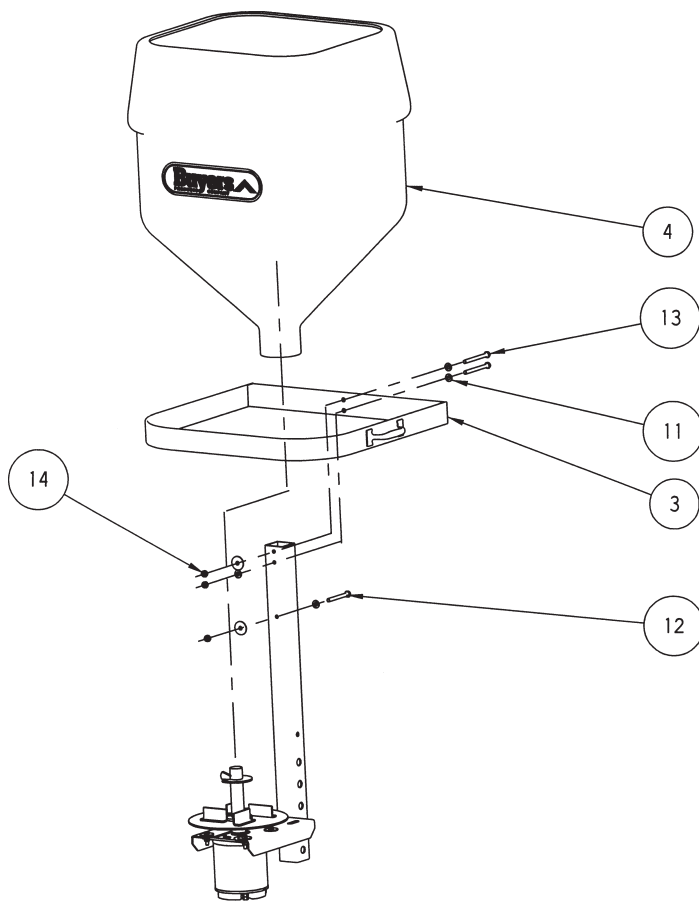

Fig. 3

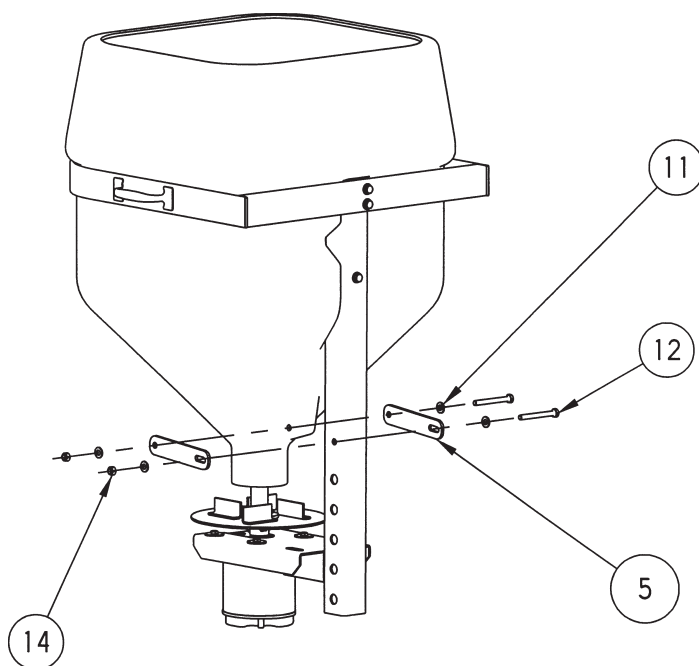

Fig. 4

Operation

Install unit on vehicle by sliding into receiver hitch. Be sure to install receiver safety pin. The wire harness should be fed through the partially opened back window of the SUV and plugged into the auxiliary power outlet in the dash board. The auxiliary power outlet of the vehicle should be rated at 20 amps – check the vehicles owners manual. **DO NOT USE FUSES RATED FOR MORE THAN 20 AMPS IN THE SPREADER WIRING HARNESS PLUG.** We recommend dumping 2-3 bags of #1 rock salt into the hopper at a time, this way there will not be a lot of extra salt in the unit when you are done. Place the lid on the hopper and secure. Start at one end of the driveway with the vehicle in low gear and idling. Start the spreader as soon as the vehicle starts to move. Do not accelerate the vehicle, best results are when the vehicle is moving in low gear at idle. Multiple passes over the driveway from both directions may be required. If the red light on the on-off switch does not turn on then check the plug connection and the fuse located inside the wire harness plug. The fuse may blow if the salt you are using is wet or chunky. The spreader is designed to use dry loose #1 rock salt, using any other material may blow fuses and/or damage the spreader. We do not recommend leaving the spreader on the vehicle when traveling on roads for long distances. If you must leave it on the vehicle when traveling, be sure the hopper is **EMPTY** and the plug is disconnected from the vehicle dash board. When the spreader is not in use empty the hopper and remove it from the vehicle. The spreader should be hosed off periodically to prevent corrosion of moving parts. Disconnect the wiring harness at the plug near the motor before hosing off spreader. Store the spreader upside down with the lid off in a dry place. Make sure the wiring harness plug and the motor is dry and free of ice before using the spreader again.

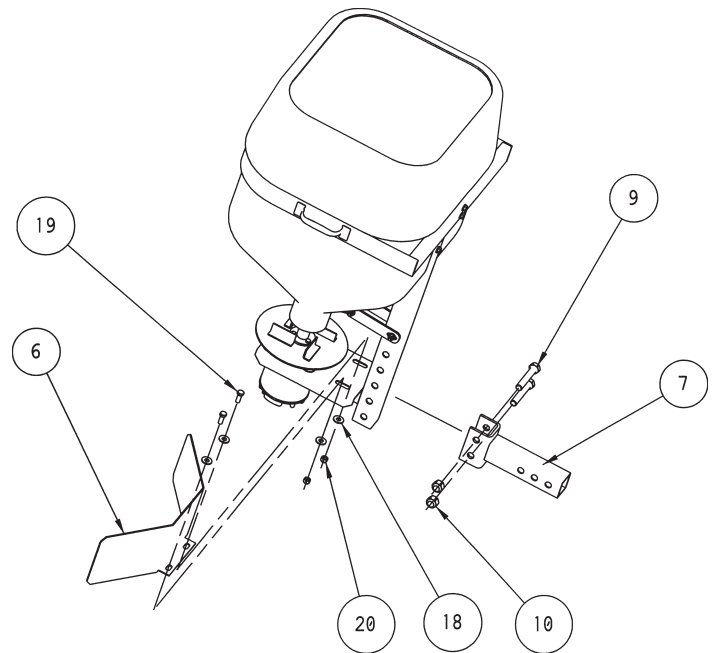

Fig. 5

FULL ONE YEAR WARRANTY

Manufacturer will repair, or at manufacturer's discretion will replace any part of this salt spreader which proves to be defective in workmanship or material under normal use for a period of one year from the date of delivery to the original purchaser. Any cost incurred in returning the product to the supplier is the responsibility of the consumer.

EXCLUSIONS

Manufacturer shall not be liable for special, incidental, or consequential damages, or for damages resulting from lack of necessary maintenance, from misuse, abuse, acts of God, or alteration of the product. Some states do not allow the exclusion or limitation of incidental or consequential damages, so the above limitation or exclusion may not apply to you.