



Quality since 1946

9049 Tyler Blvd. • Mentor, Ohio 44060  
Phone (440) 974-8888 • Fax (440) 974-0165  
Toll-Free Fax 800-841-8003 • buyersproducts.com

# Wintergate Spreader Mount 025000A

for TGS01 Series & TGS05 Series  
Tailgate Salt Spreaders

## **IMPORTANT**

Installation Instructions, Parts List  
and Maintenance Instructions

*Place in vehicle glove box after installation.*

# Installation Instructions

## 025000A Wintergate Spreader Mount

### Parts List for Wintergate Spreader Mount

ITEM	PART NO.	QTY.	DESCRIPTION
1	Truckbedrack	1	Pick-up Bed, General Dim.
2	Tailgaterack	1	Tailgate
3	Bumper	1	Bumper
4	3007514	2	Bed Rail Mount
5	3007515	2	Crossmember Bracket
6	3007512	1	Bumper Bracket, PS
7	3007513	1	Bumper Bracket, DS
8	3007793	1	Cross Member w/Handle
9	3007516	1	Cross Member
10	FCS03016250	4	Screw, HX HD Cap 3/8-16 x 2 1/2 G5
11	FWF038081006	4	Washer, Flat 3/8 SAE Zinc
12	FWL38069009	4	Washer, Split-Lock-3/8 ZP
13	FCB038016125	6	Bolt, RHSQN 3/8-16 x 1 1/4 GR5 ZN
14	FWF038100007	6	Washer, Flat 3/8 USS Zinc
15	FNE038016044	6	Nut, Nylock 3/8-16 x 7/16 Zinc
16	3007755	1	Plate, Retainer
17	B08562101	3	Pin, Hinge 5/8"
18	66050	4	Snapper Pin, 1/4 x 2, Ylw Zinc
19	1411500	2	Collar, Locking w/Setscrew
20	FWF063131095	2	Washer, 5/8 SAE Flat ZN
21	3007806	2	Pad, Foam .094 x 2.5 x 4
22	3007795	1	Retainer Nut Plate

The following are instructions for installing the Wintergate spreader mount. We recommend that this product only be installed on trucks with a step bumper. Buyers Products Company makes no claims as to the mountability of this product on a particular vehicle. Before beginning the installation procedure read the instructions thoroughly and check all parts and quantities against the parts list.

**CAUTION:**

- Never swing the spreader away from the truck with salt in the hopper
- All retainer pins must be securely in place when transporting and using the spreader
- Check torque of all fasteners on a monthly basis

### WINTERGATE ASSEMBLY

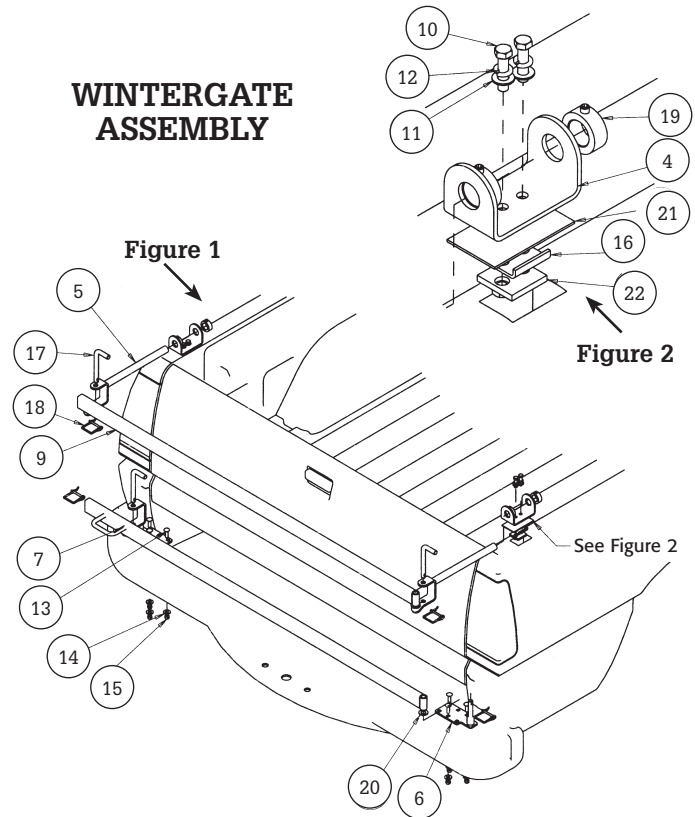

PS—Passenger Side  
 DS—Driver Side

### 1. Preparation

- 1.1 Park the truck on a level surface.
- 1.2 Installation will require two people.
- 1.3 Parts are referenced by the item numbers shown in the parts list and assembly drawing (Figures 1 and 2).

### 2. Stake pocket anchor installation

- 2.1 Mount the adhesive foam pad (21) on the underside of each bed rail mount (4).
- 2.2 Assemble the retainer nut plate (22), retainer plate (16) and bed rail mounts (4) using 3/8" hex head

screws, lock washers and flat washers as shown in figure 2. For ease of installation leave the bolts unscrewed as much as possible allowing for the retainer plate to tilt as it is installed into the pocket.

**2.3** Insert a bed rail mount assembly into the PS stake pocket.

**2.4** Make sure the retainer plate (16) is centered in the pocket and tighten the bolts until the anchor is secure but still loose.

**2.5** Slide the anchor towards the tailgate until solid against the back of the stake pocket and tighten the bolts. Alternate tightening each bolt until each is properly torqued to at least 20 ft-lbs.

**2.6** Repeat steps 2.1-2.5 for the DS stake pocket anchor.

**2.7** *If desired, the bedrail stake pocket anchors may be directly mounted to the bedrails (if stake pockets are not present). It is recommended that the nut plate be used to ensure good load distribution to prevent damage to the sheet metal.*

### 3. Crossmember bracket installation

**3.1** Insert crossmember brackets (5) into the PS and DS bedrail stake pocket anchors.

**3.2** Slide the backup locking collar (19) onto the crossmember bracket. Do not tighten.

### 4. Crossmember installation

**4.1** Position the upper crossmember (9) between the PS and DS crossmember brackets.

**4.2** Install the hinge pins (17) and snapper pins (18) on the PS and DS brackets.

**4.3** Determine the required length for the crossmembers (1/2" beyond the DS bracket), and remove and cut both crossmembers to length if desired. *On trucks with narrow tailgates, the handle on the lower crossmember may be cut off.*

## 5. Bracket alignment

**5.1** Reinstall the upper crossmember, hinge pins, and snapper pins.

**5.2** Position the PS and DS bedrail brackets so that the upper crossmember is parallel with the rear of the truck. This can be checked by measuring from a reference position on each side of the truck to the crossmember. The rear of the stake pocket anchor (if properly installed) will work. The PS bracket will be approximately 7/8" farther rearward than the DS bracket.

**5.3** Place the PS (6) and DS (7) bumper brackets on the bumper.

**5.4** Install the lower crossmember with handle (8) between the two brackets.

**5.5** Install a hinge pin (17) and snapper pin (18) in the DS bracket.

**5.6** Position the PS bumper bracket so that the crossmember when swung will not hit the rear of the truck and so that the TGS05 frame will sit squarely on the bumper. See figure 3.

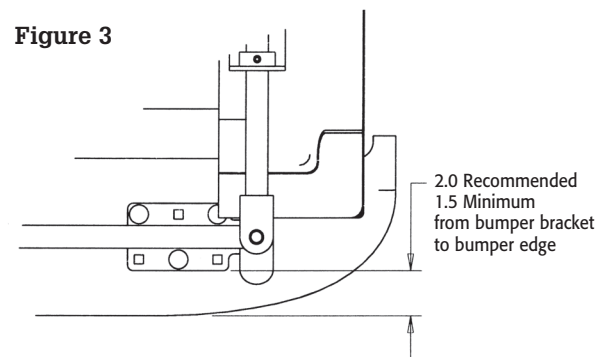

**5.7** Position the PS bumper bracket so that the hinge pin is left/right aligned with the bedrail bracket pin hole. This can be accomplished using a level held vertically against the edge of the PS bumper bracket and the edge of the crossmember bracket. **If the two brackets are not aligned, the Wintergate will not operate properly.**

**5.8** Mount the PS bumper bracket using 3 x 3/8" carriage bolts, lock nuts, and flat washers (13/14/15). Six holes are provided to ensure that at least three can be reached under the bumper.

**5.9** Position the DS bumper bracket so that the lower crossmember is parallel to the rear of the truck. The left/right alignment of the DS bumper bracket is not critical. Make sure that the DS bumper bracket does not interfere with the tailgate or the handle on the lower crossmember. The DS bumper bracket does NOT need to be left/right aligned to the DS bedrail bracket.

**5.10** Mount the DS bumper bracket using 3 x 3/8" carriage bolts, lock nuts, and washers.

**5.11** Align the bedrail and bumper brackets in the front/rear direction using a level held against the fronts of the crossmembers on each side. When aligned, tighten down both set screws on the PS and DS stake pocket anchors. *Due to irregularities in the bumper/ plastic covering it is possible that the two crossmember faces may not be square with each other. If this is the case, the final front/rear alignment may be completed after the spreader frame is mounted. To ensure proper alignment, it may be necessary to completely remove plastic bumper cover.*

## 6. Spreader Mounting (See Figure 4)

**6.1** Using 2 x 3/8" machine screws, flat washers, and lock nuts (6/7/8), attach the plastic foot covers (4) to the feet of the spreader frame.

**6.2** Drill 2 x 1/4" holes in the feet of the spreader using the smaller holes in the covers as a guide.

**6.3** Using 2 x 1/4" machine screws, lock washers, and nuts (9/10/11), bolt the second end of each foot cover to the spreader feet.

**6.4** Place the spreader on the bumper and clamp each side of the spreader frame to the upper crossmember with a C-clamp.

**6.5** Attach the spreader to the lower crossmember using 2 x 3/8" U-bolts (12) and 4x washers and nuts (7/8). *Note: TGS01 only, 2x 7/16" holes will have to be drilled through the rectangular tubing. Enlarge the outer hole to 3/4" to allow access for holding the u-bolt nut with a deep socket.*

**6.6** Loosen the C-clamps on the upper crossmember (DO NOT REMOVE) and raise the upper crossmember so that it is centered between two of the existing holes on the spreader frame. The upper crossmember

MUST NOT be resting on the lower surface of the crossmember brackets – if it is, raise it to the next set of holes. Attach the spreader to the upper crossmember using 2 x 3/8" U-bolts and 4x washers and nuts.

*Note: TGS01 only - 2x 7/16" holes will have to be drilled through the angle brackets mounted to the side of the spreader (refer to TGS01 instructions).*

**6.7** Check all nuts and fasteners and remove C-Clamps.

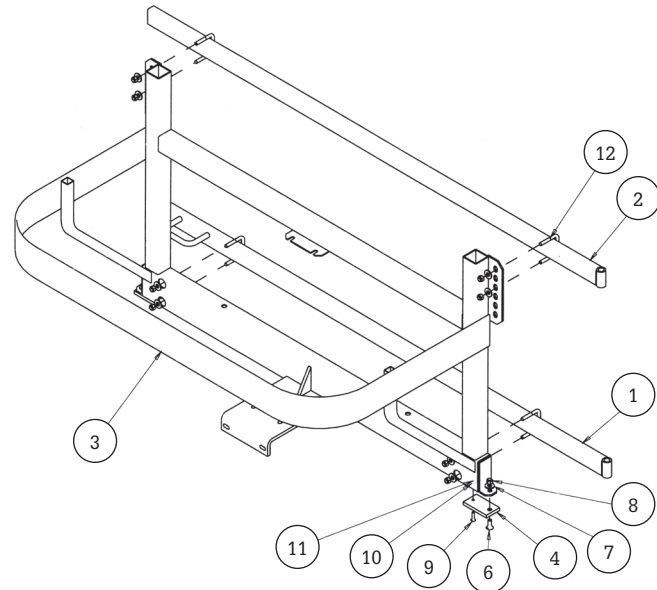

Figure 4. Spreader Mount

### Parts List for Spreader Mount

ITEM	PART NO.	QTY.	DESCRIPTION
1	3007793	1	Cross Member w/Handle
2	3007516	1	Cross Member
3	3006702	1	Assembly, Frame Weldment, TGS05B
4	025865	2	Foot, TGS05 Wintergate
5	66110	1	Pin, 3/4 Hitch w/Hair Pin
6	FMS038016100	2	Screw, Slotted CSNK HD 3/8-16 x 1 ZN
7	FWF038100007	10	Washer, Flat 3/8 USS Zinc
8	FNE038016044	10	Nut, Nylock 3/8-16 x 7/16 Zinc
9	FMS025020100	2	Screw, Slotted CSNK HD 1/4-20 x 1 ZN
10	FWL025050006	2	Washer, 1/4" Spring Lock NS
11	FNH02502021	2	Nut, Nex 1/4-20 Zinc NS
12	3007797	4	U-Bolt, .375 Dia.

### Full One-Year Warranty

Manufacturer will repair, or at manufacturer's discretion will replace any part of this wintergate which proves to be defective in workmanship or material under normal use for a period of one year from the date of delivery to the original purchaser. Any cost incurred in returning the product to the supplier is the responsibility of the consumer.

### Exclusions

Manufacturer shall not be liable for special, incidental, or consequential damages, or for damage resulting from lack of necessary maintenance, for misuse, acts of God, or alteration of product. Some states do not allow the exclusion or limitation of incidental or consequential damages, so the above limitation may not apply to you.